

We Walk  
Alongside The World

YIZUMI 伊之密

We Walk  
Alongside The World

# CRAFT

VOL.25  
2021

YIZUMI Customer Magazine

**P03 Enterprise**

Global Sales Exceeded 2 Billion  
in 2020  
Focus on Electric Injection Molding  
Machine in 2021

**P11 Chinaplas**

FF Series Electric Injection  
Molding Machine  
Functions Upgrade for Smart  
Production

**P17 Customer Story**

W1 Series—Tailor-made for  
the Deep-cavity Products

**P21 Product**

Worry about the Clamping  
Force Issue?  
Try This New Function...



Connect  
China and Europe  
Smarter Future



www.yizumi.com



YIZUMI\_Official

YIZUMI\_Official



**P03 Enterprise**

Global Sales Exceeded 2 Billion in 2020  
Focus on Electric Injection Molding Machine in 2021



**P07 Chinaplas**

Fancier Surface and Lower Cost Thanks to RIM 2.0

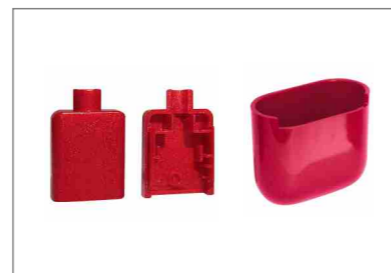

**P11 Chinaplas**

FF Series Electric Injection Molding Machine  
Functions Upgrade for Smart Production



**P17 Customer Story**

W1 Series—Tailor-made for the Deep-cavity Products

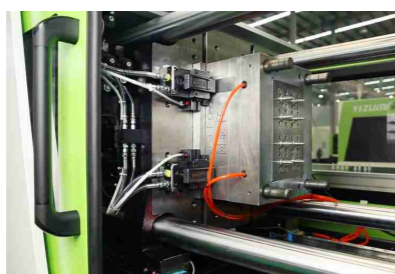

**P21 Product**

Worry about the Clamping Force Issue?  
Try This New Function...



**P23 YFO**

YIZUMI Factory Outlet

## New Goal: To become a world's top five enterprise in the next five years

A stable strategy deployment can enhance a company's resilience against external changes.

In 2020, the sudden outbreak of Covid-19 exposed the global plastics processing industry to an unprecedented challenge. YIZUMI's performance in the first quarter of 2020 also declined due to the pandemic impact. Thanks to years of preparedness in products, markets and lean production, YIZUMI's powerful risk capacity allows it to quickly return to the fast track of high-quality development as soon as the outbreak is stabilized and wrapped up the year with a strong performance report. YIZUMI's 2020 earnings report shows that the company expects to achieve total operating income of 2.72 billion CNY, an increase of 28.7% year on year, and is expected to achieve operating profit of 390 million CNY, an increase of 77.4% year on year, laying a solid foundation for the development in 2021.

As 2020 came to an end, YIZUMI also concluded its 2018-2020 three-year deployment plan. According to the current competitive landscape in the global machinery and equipment industry, YIZUMI has launched a new round of 2021-2025 five-year development plan, putting forward new five-year development goals. YIZUMI aims to boost the overall competitiveness of injection molding machines to become the global top 5 of the industry and continuously increase its market share at overseas sales CAGR not less than 20% in the next 5 years.

YIZUMI's confidence in achieving this challenging goal comes from the recognition by the global K1 customers in recent years. These customers include the world's leading auto parts manufacturers and industry leaders in the 5G, building materials, sanitary ware supplies, and medical packaging fields. As they chose YIZUMI, their weight in YIZUMI's market share is continuously rising, indicating the advantages and competitiveness of YIZUMI in the global market.

How will YIZUMI pursue the new goal in the next five years? YIZUMI has started to implement its comprehensive market deployment plan and the works are carried out in an orderly manner.

In terms of product and technological innovation, YIZUMI will continue to develop new products, new technologies and new processes to further improve the application capacity of integrated solutions, develop and implement the high-end product roadmap, and set up technology pre-research teams to accelerate the development and pre-research of key technologies.

In the global market, YIZUMI will further enhance the organizational capacity through organization reform and promoting the marketing service system, bringing it closer to the market and customer needs. The company will beef up the level of specialization and technical marketing capabilities, and accelerate the construction of the overseas technical service centers in key regions and markets to establish global customer service processes and procedures with integrated and unified standards.

In terms of manufacturing and operational system construction, YIZUMI will speed up the construction and transformation of digital factories to establish first-class quality management systems and processes. It will continuously improve product quality to meet the requirements of global high-end customers on full process management of product quality and delivery.

Over the past 19 years, YIZUMI has encountered many challenges and always fought hard, and never backed down. In the next five years, with becoming a global top 5 company as the new goal, YIZUMI will continue to create value for its customers by providing competitive, technology leading integrated solutions to customers around the world. YIZUMI sincerely hopes to collaborate with the customers and partners worldwide for mutual success in the new journey.

First Issue, 2021  
For internal distribution only  
General Advisers: James Zhang, Wang Shihai, Li Binli  
Chief Editor: Sabrina Zhao  
Associate Editors: Li Miaoxian, Li Junyi  
Text and Cover Design, and Electronic Page Makeup: Tan Guohui  
Technical Advisers: Li Donghai, Jiang Xiaojun, Li Baojian, Hou Yongping, Jin Hui, Glory Chen

Published by the Craft Editorial Dept.  
Guangdong Yizumi Precision Machinery Co., Ltd.  
Address: No.22, Keyuan 3 Road, High-tech Zone, Ronggui, Shunde, Foshan City, Guangdong Province, China, 528306  
Cell: +86-757-2926 2000 Fax: +86-757-2926 2266  
Website: www.yizumi.com  
E-mail: Li Junyi@yizumi.com

Disclaimer: All material is accepted on the understanding that it is copyright free. Craft accepts no liability for any subsequent copyright issues.



■ China Wusha Factory 2

## Global Sales Exceeded 2 Billion in 2020 Focus on Electric Injection Molding Machine in 2021



From the shortage of medical PPE supplies to the sharp increase in food packaging consumption, release of regulations banning or limiting the use of plastic, skyrocketed prices for raw materials ... the plastics industry went through a tough year in 2020.

In 2020, YIZUMI worked closely with the customers to overcome the difficulties. Thanks to years of proactive investment in products, markets, and lean manufacturing, the sales of injection molding machines worldwide rose against the trend by nearly 40%, exceeding 2 billion CNY, a record high.

In 2021, as the global situation is still full of uncertainty and changes, how will YIZUMI tackle the challenge?

### 2020

#### Sales growth of small and medium-tonnage machine against the trend

In 2020, the rapid recovery of China's domestic market and the surge in export orders contributed significantly to the growth of the industry. The demand in 3C, medical, packaging, small appliances, 5G, building materials, and other fields is particularly strong, thus leading to a sales surge in YIZUMI machines such as the three-platen servo energy-saving injection molding machines, precision electric injection molding machines, and multi-component injection molding machines. Among them, the small and medium-tonnage injection molding

machines had the most prominent performance.

“This is facilitated by YIZUMI’s proactive implementation of lean production.” said Tao Zhang, YIZUMI Deputy Managing Director & General Manager of Injection Molding Machine Division. The assembly line for small and medium-tonnage models was successfully put into operation in early 2020 after the introduction of the lean manufacturing mode. It has greatly enhanced the company’s production efficiency and delivery capacity with an increase of 60% in production capacity year on year, making significant contributions to the rapid growth of the year.

While the China’s market soared, the performance of overseas market also exceeded the expectation, achieving a double-digit growth. The accomplishment does not come easy as the pandemic is sweeping across the world. “For years, we have been continuously investing in building our global sales and service network. Our uninterrupted service is still maintained even during the pandemic outbreak. Combined with the remote technical support and training provided by the service teams at the headquarters, our service is well approved by the overseas customers, enhancing their confidence in buying YIZUMI machines.”





### Set foot in the global high-end market

Among the highlights of 2020, the most notable is that YIZUMI added more than thirty K1 customers to its customer list, including the world's leading auto parts manufacturers such as VALEO, MAHLE, Rochling, Shanghai Tongling, Changchun FAWSN Swell Automobile Parts, companies in the 5G field such as Foxconn, TP-LINK, FRD, COTRAN, brands in building materials and sanitary ware field such as ARROW, WIRQUIN, Rifeng, Xiongsu, as well as Jinyu and Lianchang in the medical packaging industries.

"Though these K1 customers from different fields have various personalized requirements for machine performance and configuration, our solutions meet these requirements quite well and gain customer recognition." said Tao Zhang.

In order to compete for these K1 customers in the high-end market, YIZUMI upgraded its products across the board in 2020, including the three-platen injection molding machines, two-platen injection molding machines, all-electric injection molding machines, multi-component injection molding machines, new processes and new technologies. YIZUMI completed a number of new product development projects in each sector and launched onto the market.

For example, the 3200DP auto bumper molding system completed the construction of all automated units and detection units required by the fully automated auto

bumper molding. It offers a stable system operation with rapid mold changing, high-efficient molding process and industry-leading technical indicators, thus providing customers in the auto industry an integrated solution.

To better meet customers' personalized needs of multi-component products, YIZUMI also completed the development of various multi-component machines including the 1600D1 three-color two-platen injection molding machine, 420A5-EU two-color injection molding machine, 1000A5 two-color injection molding machine, and 260A5 hydraulic and electric three-color injection molding machine and introduced them to the market in a timely fashion.

#### 2021

### Deployment in key markets worldwide to tackle the post-pandemic economy

As the market started to heat up last year, the market demand for injection molding machine maintains strong this year. The number of purchase orders YIZUMI has in hand that is waiting to be delivered is at a record high. The production system is running at full capacity to expedite the delivery. YIZUMI is optimistic about the overall development of the industry this year. As Tao Zhang said, "Although the continuous outspread of Covid-19 in some countries, many Covid cases are gradually under control, the economy is expected to rebound in the second half of the year for another round of rapid growth."

YIZUMI will step up its efforts this year to promote globalization and prepare itself for the upcoming market boom. Tao Zhang believes that after experiencing the tough time of the pandemic, countries have recognized the need to strengthen their industrial chain. The global industrial layout and ecology may face continuous changes and adjustments. "YIZUMI will get itself ready by strengthening our capacity to serve the global market and customers, providing better products and services, and enhancing our competitiveness in a changing market."

According to the report, in 2021, YIZUMI will complete the construction of the Nuremberg Technical Center in Germany and the Brazil Technical Center that were delayed due to the impact of the pandemic, push forward the construction of the new plant in India, open a technical service center in Thailand, and assess the feasibility of a manufacturing plant in Mexico.

Among them, the new plant in India has started planning and construction in the fourth quarter of 2020. The first phase includes the construction of a production facility with an area exceeding 20,000 square meters and is scheduled to be completed and put into operation in mid-2022. It will create a production capacity to meet the needs for injection molding machines amounting nearly 300 million CNY. As an important strategic market outside of China, the completion of the new plant in India will provide a new platform to improve the local manufacturing capacity.



### Promote electric injection molding machines

While YIZUMI is expanding its market share worldwide to improve global competitiveness, it will continue to develop new products, technologies, and processes to enhance the application capacity of integrated solutions. "YIZUMI's strategic priority in the next five years is to enter into the global market for high-end customers. To achieve this goal, we will develop and implement plans for high-end products as well as establishing technology pre-research task teams to accelerate the development of new and critical technologies." Tao Zhang said. YIZUMI will actively cultivate new "engine" of growth - electric injection molding machine this year and beef up the efforts in product serialization and market promotion.

In the past two years, YIZUMI has been increasing its investment in upgrading electric injection molding machines and independently developed the servo direct control technology (SDC), the smart clamping force management(SCFM) system, the smart injection control technology, closed-loop injection pressure control technology, as well as the contact-free tie bar technology and built-in hydraulic pump station. While improving the core performance of precision injection molding, these technologies make the machines cleaner and more adaptable to products and molds.

The sales of the upgraded electric injection molding machines continue to rise and the growth seems promising. At the DMP Great Bay Expo, YIZUMI's 300T FF electric injection molding machine made its debut, indicating the transformation of YIZUMI's product lines toward the development of medium and large tonnage models.

This year, YIZUMI will continue adhering to its established development plan to develop electric models of 1000 or lower tonnage. The injection unit will employ a modular approach to allow more flexible applications in hydraulic and electric machines and multi-component machines. In the meantime, YIZUMI will continue to improve the machine's functionality in terms of machine intelligence and industry 4.0 enabling to enhance smart processing management, data collection and analysis, helping customers to implement industry 4.0 and increase their values. In addition, the FEII series developed on the basis of the FF standard models will be available in 2021. In order to meet the growing needs of customers, YIZUMI will also promote the assembly lines for electric injection molding machines to accelerate the expansion of production capacity.



# Electric



■ 3200DP Auto Bumper Molding System



■ Injection Molding Workshop in BYD



■ Injection Molding Workshop in ARROW



■ YIZUMI Electric Injection Molding Machine Workshop

# D1 Series Two-platen Injection Molding Machine Fancier Surface and Lower Cost Thanks to RIM 2.0



YIZUMI presented ReactPro Integrated Solution of Polyurethane and Injection Molding (short for RIM) at CHINAPLAS 2021 after the CHINAPLAS 2019 and Germany K show 2019. The 2.0 version of the solution produces parts that are not only soft-touching, self-repair, corrosion-resistant, and scratch-resistant but also have a high-gloss, matte appearance. The total cost will be reduced significantly when adopting domestic PU materials.



The ReactPro Solution is jointly developed by YIZUMI and FRIMO Germany, which offers one-step injection molding for parts and their polyurethane coating by a single injection molding.



The ReactPro solution adopts the InPUR "1+2" mold technology jointly developed with GK Concept Germany, in which two PU molds alternately coordinate with one injection mold to create a shorter cycle time. Although the polyurethane reaction time still

takes about 2 minutes, the molding cycle is greatly shortened to about 1 minute. In addition, the InPUR "1+2" mold technology doesn't require any swivel units such as conventional horizontal or vertical rotary tables and therefore the design is more compact, considerably saving the cycle time of batch production.

The engine cover with the soft and self-repairing PU surface below is produced by the ReactPro solution. Its surface transparency and color can be adjusted according to the needs of the customer, and 3D depth surface effect is also available for the customers. Additionally, high-gloss effects and matte effects can appear on the same surface. The PU thickness of the engine cover is about 0.5-0.6 mm, and the PU material we use is self-releasing, which makes it very convenient for the entire production.

YIZUMI's ReactPro solution is suitable for the production of new-generation automotive upholstery (such as instrument board, door panel, and intelligent component). Some automotive upholstery from BMW and Benz has used polyurethane coating on its decorative surfaces and functional surfaces. Meanwhile, the polyurethane coating has tremendous potential in the 3C and appliance industries due to its good performance, raising the possibility of better product design.



Product: Engine Cover  
Molds: InPUR 1+2 innovative molds  
Machine: UN500DP Two-platen Injection Molding Machine  
Material: AKROMID® B3 GF 15 1 black + SHGPuR  
Part size (LxWxH): 400x350x25 mm  
Part weight: 470g  
Cycle time: 60s



※ 1. The Data above were acquired by testing in YIZUMI's factory, only for your reference. The specific data please refer to the actual equipment.  
2. The product pictures and content above are only for your reference. The product effects (including but not limited to appearance, color and size) may be slightly different, please refer to the actual products.

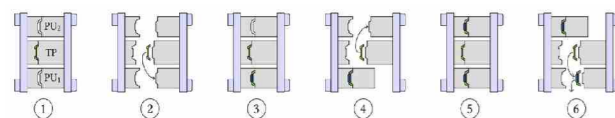

## Technical Q&A

—ReactPro Polyurethane and Injection Molding Integrated Solution



**Q: How can ReactPro achieve injection molding and polyurethane coating in one single step?**

A: The one step parts production process of injection molding and polyurethane (PU) coating is made possible through a combination of injection molding machine and PU system. The key is the mix head which connects the two machines.

Both injection mold and PU mold are mounted on the injection molding machine with the PU mold connected with the PU system through the mix head. The plastic substrate is made first by the injection molding machine and then moved to the PU mold by a robot. PU material is formed by two groups of ingredients: A and B (polyol and isocyanate). They are stored in two storage tanks of the PU system separately and conveyed to the mix head through feeding pipes. The A and B materials will be rapidly and evenly mixed in the mix head under high pressure and then injected into PU mold cavity by the injection nozzle. The ingredients will react under certain conditions and solidify on the surface of the plastic substrate. This is a continuous process, which saves the time and cost of bonding the plastic substrate and PU layer as semi-finished products. It greatly improves the efficiency and quality of the production.

**Q: What is the hardness of the high gloss surface treated by ReactPro technology?**

A: Soft touch PU on engine cover: Shore hardness about 80A

Hard touch PU on engine cover: Shore hardness about 70D

Surface hardness can be adjusted according to customer's requirements (in the range of Shore hardness 70A-80D)

**Q: How thin the PU layer can be by using ReactPro technology?**

A: With part yield guaranteed, the thickness of PU coating can reach 0.3mm for parts with simple structures such as flat parts. If the part has a more complex design with curved surface, rounded corners or different thickness requirements on the same plane, the thickness may be increased according to the customer's requirements and the performance supported by the PU material.

**Q: What are the common defects of PU coating?**

A: If the processing conditions are not controlled properly during the injection process, you may find blowholes in the PU coating or short shots in the mold cavity. In such case, you need to increase the pressure in the mold to solve the problem.

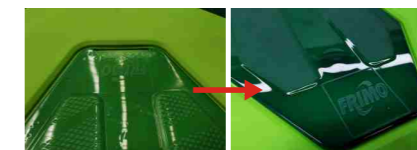

**Q: What requirements does the PU coating have on the sprue design? Is there any special requirement on the shape of the sprue?**

A: PU materials have low viscosity and good fluidity after melting. Similar to the design requirements for most materials, the layout of

sprue should follow the principle that results in shorter runners and properly allocated to cover all sections of the mold through mold flow analysis.

The sprue feeding process is similar to water control in the hose. With the same amount of PU supply, the sprue that has a wide and round shape will show less pressure and larger flow. When the shape of the sprue is flattened, it will demonstrate higher pressure and smaller flow. Therefore, it needs to be adjusted according to the specifications, processing temperature, and melt viscosity of the PU material.

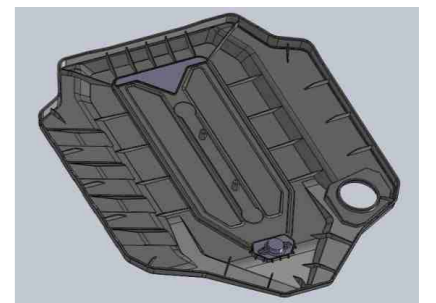

※ 1. The Data above were acquired by testing in YIZUMI's factory, only for your reference. The specific data please refer to the actual equipment.  
2. The product pictures and content above are only for your reference. The product effects (including but not limited to appearance, color and size) may be slightly different, please refer to the actual products.

## FoamPro Packaging Microcellular Foaming Injection Molding Solution New Direction for Biodegradable Injection Molding and Irregular-design Packaging



The packaging manufacturers have been asking for new technological breakthroughs to optimize product design and texture. MuCell microcellular foaming technology can give them a hand and provide a brand-new solution.

During the MuCell foaming process, supercritical fluid (nitrogen or carbon dioxide) is injected into the polymer melt. After being injected into the cavity, the polymer melt starts to form bubbles and expand. When the filling completes, the foaming stops because of melt cooling and limited swelling capacity. A microcellular structure is ultimately formed in the product.

It is characterized by reducing the product weight, cycle time, warping, and clamping force, providing unique advantages over conventional injection molding.



Based on the in-depth development of MuCell technology, YIZUMI's FoamPro microcellular foaming solution has been applied in the fields of automobiles and home appliances. At CHINAPLAS 2021, the YIZUMI FoamPro solution was equipped with PAC250K high-speed injection molding machine, MuCell equipment, an in-mold labeling system, and a two-cavity hot runner mold, displaying more high-quality and environmentally-friendly packaging production with more design freedom.

In this application example, FoamPro microcellular foaming solution improves the melt fluidity and eases the molding,

especially the molding of full biodegradable plastic. Nowadays, the demand for the fully biodegradable PLA is growing in the packaging industry. However, there are some application problems because of its melt index (3-5MFR), poor fluidity, difficult molding. The MuCell technology will contribute to better fluidity and easier part molding with the mixture of the supercritical gas and plastic melt.

FoamPro can also provide flexible design of wall thickness, improve part size stability and reduce warpage.

Meanwhile, the lightweight feature of MuCell technology is reflected: reduction in part weight by 5%, injection pressure by 15%, and clamping force by 20%. More cost-saving and environmentally friendly compared with traditional packaging part.

Moreover, MuCell technology also upgrades the part quality, namely microcellular foaming packaging is thicker, stronger, and more heat-insulated (20%-30% up) than regular injection molding packaging part at the same weight.

Overall, FoamPro microcellular foaming packaging injection molding solution has unique advantages in part molding, design freedom, warpage reduction, energy-saving, quality, etc. It is especially suitable for packaging production requiring high quality and flexible design.



Product: Microcellular Foaming Container.  
Number of cavities: 2  
Capacity: 1L  
Part weight: 25.6g  
Cycle time: 6.5s  
Partners: Trexel, 2Limit, SWITEK, Sabic, Bowei



※ 1. The Data above were acquired by testing in YIZUMI's factory, only for your reference. The specific data please refer to the actual equipment.  
2. The product pictures and content above are only for your reference. The product effects (including but not limited to appearance, color and size) may be slightly different, please refer to the actual products.

## NSW Series Piggyback Multi-component Injection Molding Machine One-Step Production of Triple-color Electric Toothbrush Handle



With more than 69% sales growth for three years in a row, the electric toothbrush, a favored item in the background of consumption upgrade, has maintained a strong growth momentum in the field of small household appliance for personal care. However, most electric toothbrush production still adopts overmolding and assembly processes, which require more floor space and labor but with low efficiency and poor product quality.

Traditional production modes led to fierce homogenous competition, which seriously deviates from the national initiative: transformation and upgrading, quality improvement, efficiency increase, and cost reduction. The sustainable development of enterprise cannot be guaranteed effectively.

YIZUMI NSW series piggyback multi-component injection molding machine is equipped with hydraulic and electric hybrid structure, precise positioning technology for servo rotary shaft, triple-color molding technology, process tracking technology, etc., which meets the requirements of molding precision, high efficiency, customization and improves plant utilization, providing a more cost-effective solution for multi-component molding.

At CHINAPLAS 2020, a YIZUMI piggyback multi-component injection molding machine combined a triple-color mold and a V-type electric injection unit, to produce triple-color electric toothbrush handles composed of PC shells, TPU buttons, and transparent ABS indicator lights in one step. Laser marking and process tracking technology were also applied.

High flexibility plays an essential role in multi-color injection. The transparent indicator lights mentioned above have light-weight and thin-wall shells, which require accurate

control of injection pressure and speed. Precision injection electric injection units can avoid flash and short shots, making molding more stable. The hydraulic and electric hybrid technology allows agile switching between hydraulic injection units and electric injection units according to customer requirements. For example, adopting an electric injection unit can satisfy the demand of precision molding and optimize the investment cost.

### Value Advantages: +

- ◆ Precise positioning of three-location rotary shaft: the rotary shaft servo system adopts DCPC three-location positioning technology to offer quick, accurate positioning control;
- ◆ Customized tracking mode of manufacturing information: tracking products using QR codes to meet customized requirements;
- ◆ Flexible module combination: The nozzle center distance is adjustable on the piggyback series machines, which can be equipped with a turntable or a rotary shaft module. Hydraulic or electric injection units are also optional. Agile combination would be conducive to obtaining better investment projects;



Product: Tricolor Electric Toothbrush Handle  
Number of cavities: 1+1+1  
Material: PC+ABS+TPE  
Part size (LxWxH): 156x32x30mm  
Part weight: 42g/piece  
Cycle time: 55s



※ 1. The Data above were acquired by testing in YIZUMI's factory, only for your reference. The specific data please refer to the actual equipment.  
2. The product pictures and content above are only for your reference. The product effects (including but not limited to appearance, color and size) may be slightly different, please refer to the actual products.

# FF Series Electric Injection Molding Machine Functions Upgrade for Smart Production



In the face of the outbreak of COVID-19, recruitment difficulties, scarcity of skilled workers, and homogeneous competition in the industry, plastic processing enterprises are accelerating the process of smart manufacturing to reduce reliance on labor and improve risk resistance capacity.

FF series electric injection molding machine, one of the YIZUMI's leading machines, has long been devoted to breaking the technical bottleneck in smart injection molding systems, to continuously meet customer's new demand for smart machines and intelligent injection molding systems.

This year, YIZUMI brought the FF series electric injection molding machine equipped with a number of smart functions to the CHINAPLAS, presenting the smart machine charm. YIZUMI also demonstrated two solutions at site—the 64+64 stack mold solution for top and bottom USB data cable and the automation solution for headphone charging case, to allow customers to have a multifaceted experience on smart injection molding processes.

## SCFM Smart Clamping Force Management

The SCFM system independently developed by YIZUMI is a new upgrade based on the auto adjustment mode according to the clamping force. The SCFM system offers functions such as real-time measuring, smart recommendation, no-stop adjustment, and auto-holding to assist operators controlling the injection molding machine in a quick and easy way. With the help of SCFM system, injection molding machine can produce qualified products according to the reasonable clamping force set by the injection molding process.

- ◆ Real-time measuring: Directly view the clamping force in real-time through PC interface;
- ◆ Smart recommendation: Intelligently recommend the most appropriate clamping

force to customers through online equipment monitoring;

- ◆ Auto-holding: Clamping force can be maintained for an extended time due to dynamic correction during machine operation;
- ◆ No-stop adjustment: Directly input the value of the clamping force on PC screen. The machine will adjust the clamping force within two to three trials to save operating time;

## SIC Smart Injection Control Technology

Through a software-controlled algorithm, the SIC technology of the FF series electric injection molding machine can control the injection end position to improve injection precision.

- ◆ Improve the stability of product weight and the product dimensional accuracy;
- ◆ Effectively solve the imbalanced filling issue during injection molding: Eliminate short shot, flash and improve the balance of filling;
- ◆ Control peak pressure: Reduce the internal stress of product. Eliminate deformation and differences in optical characteristics caused by imbalanced internal stress;

## Automatic Quality Sorting System

Specification range of qualified products is determined by key process parameters, such as injection and pressure holding time, injection starting position, minimum buffer, injection peak pressure, etc. thus providing guidance for automatic quality inspection. It can identify and distinguish qualified and non-qualified products to avoid defects being mixed into the qualified product batch.

The automatic quality sorting system acts as the inspector who can mitigate the product quality risk by detecting equipment issues in a timely manner during the process.

## Two-stage Clamping + Low Pressure Injection

Mold close with a low clamping force firstly. When plastic melt reaches certain position, mold closing shall be enhanced to reach the pre-set clamping force until finished molding process.

This function can not only optimize the minimum wall thickness of products made by injection molding machine of the same clamping force, injection pressure and speed, but also effectively eliminate the internal stress of the product and reduce the required injection speed and the maximum injection pressure.



## Solutions:

### 64+64 Stack Mold Solution for Top and Bottom Case of the USB Data Cable

With the above smart functions, combined with the stack mold technology and the automated sprue separation technology, FF240 electric injection molding machine demonstrated the solution for the 64+64 top and bottom case of the USB data cable.

In this solution, though the top and bottom cases of the USB data cable have different

designs and weights, YIZUMI has managed to achieve the production with two molds in one machine at the same time, improving the productivity significantly.

More importantly, FF electric injection molding machine has the advantage of high injection speed and stability, smart auxiliary equipment, which effectively improve the qualified rate and output efficiency, increase the investment income of customers and create the maximum value for customers.

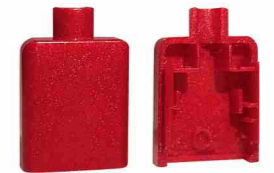

Product: USB Connector  
Number of cavities: 64+64 stack mold  
Material: spray-free ABS  
Part size(LxW): 22x15mm  
Part weight: 0.6g  
Wall thickness: 1.2mm  
Cycle time: 15s

### Integrated Solution for Headphone Charging Case

As one of the key displays at the smart manufacturing tech zone of the CHINAPLAS 2021, FF120 electric injection molding

machine was equipped with SCFM system and SIC technology, as well as functions such as sprue removal, punching and automatic packing to demonstrate the automated solution for the headphone charging case.



Product: Headphone Charging Case  
Part weight: 47g  
Wall thickness: 1.8mm  
Material: ABS  
Cycle time: 30s

※ 1. The Data above were acquired by testing in YIZUMI's factory, only for your reference. The specific data please refer to the actual equipment.  
2. The product pictures and content above are only for your reference. The product effects (including but not limited to appearance, color and size) may be slightly different, please refer to the actual products.

# Data Transmission at One Click! YiMES Intelligent Integration Process Control Function



Input errors and tedious adjustments may affect production efficiency when inputting parameters separately by hand on injection molding machines and peripherals during plastic manufacturing. The new function of YIZUMI YiMES (Intelligent Manufacturing Execution System)—intelligent integration process control is able to upload and synchronize production data to the high-end injection molding machines and peripherals, and achieve process monitoring as well as early warning.

YiMES is an intelligent system developed based on Yi+ platform (YIZUMI Intelligent Equipment Industry Internet Platform). It provides professional tools involved management in order, production, quality, process management, energy management and mold, etc., to meet the requirement of cost down, quality improvement, efficiency increase and further comply with the trend of digitization and intellectualization in the plastic manufacturing industry.

- ◆ No need of full-time IT personnel, network construction and computer room;
- ◆ The system is open to the standard interface, connecting with the mainstream

ERP system, and supporting the access of mainstream brand equipment at the device end;

- ◆ The system is easy to operate, easy to learn and get started;
- ◆ 3 weeks to go, enabling enterprises to quickly realize intelligent digital production;
- ◆ Achieve financial-class of chip data encryption with second-level certification of network security to ensure the security of customer data;

At CHINAPLAS 2021, intelligent integration process control and energy-saving drying system, the new functions of YiMES have been officially releases, to create new values for customers in terms of process management, energy saving, and cost down.

## Intelligent Integration Process Control

- ◆ The production date will be uploaded and saved on the cloud or server;
- ◆ The production data can be uploaded and synchronized to the high-end intelligent

equipment and peripherals, no need to input and adjust data by hand;

- ◆ Key data monitoring and early warning during production, notify the responsible person in time;

## YIZUMI Energy-saving Drying System

- ◆ Monitoring and early warning during drying and heating, notify the responsible person in time;
- ◆ Automatic calculation of power cost during processing;
- ◆ Energy saving analysis, statistics on cumulative power saving and power consumption, peak and valley analysis of power consumption;
- ◆ Energy consumption analysis of single product;



※ 1. The Data above were acquired by testing in YIZUMI's factory, only for your reference. The specific data please refer to the actual equipment.  
 2. The product pictures and content above are only for your reference. The product effects (including but not limited to appearance, color and size) may be slightly different, please refer to the actual products.

# YIZUMI' s Integrated Solution for Automated Trolley Wheel Production: Unmanned Production Lines are Put into Operation



At YIZUMI' s injection machine manufacturing workshop, an automated trolley wheel production line is currently being put into operation. From material feeding to injection molding, inserts conveying and inserting, product picking up, packing and placing, warehousing, etc., the entire production process runs automatically. The trolley wheel produced will be used as an assembly unit for injection molding machine, eliminating the need for external procurement.

This is an all-new trolley wheel production automation solution created by YIZUMI that integrates the self-developed mold design, injection molding machine, non-standard automatic equipment, and MES system to form a data- and information-driven, standardized automated production system.

As a benchmark project reflecting YIZUMI' s capabilities in system integration, the integrated solution for automated trolley wheel production involves technologies covering the entire plastic processing ecology encompasses raw materials, molds, processes, injection molding equipment, automation units, and industrial interconnection technology. Equipped with the Direct Compounding Injection Molding (DCIM) technology, drying-free system, UN160A5S injection molding machine, 4-cavity mold, robot, post-processing automated units (SCARA robot, stacker, finished goods storage module, heating unit for materials loaded with bearings, low-speed granulator, storage container, AGV trolley, and safety fence). Integrated automated production line handles the entire process from raw material to finished goods warehousing.

## Raw material processing: Direct Compounding Injection Molding (DCIM)

The automated trolley wheel production starts from material mixing.

With the Direct Compounding Injection Molding (DCIM), an all-new process developed by YIZUMI, the commissioning engineer can set the weight ratio of raw materials on the operation panel interface - 70%PA6+30%GF and adjust the feed speed for hunger feeding. DCIM process puts the raw materials into production directly without the extrusion and pelletizing, achieving higher energy efficiency and a more environmentally friendly process while reducing the costs of raw material mixing, packaging, and logistic support.



## Injection Molding:

### Highlight ①: Drying-free processing technology

During the injection process, due to the hygroscopicity of PA material, it generally requires a drying treatment in advance to avoid material degradation and gas marks on the product.

YIZUMI' s integrated solution provides a new technology that requires no drying treatment, namely extruding moisture from PA6 material by using a screw of special structure during plasticizing process. The extruded moisture will then be extracted by a vacuum generator mounted in the middle of the plasticizing barrel to achieve the drying-free effect. The energy-efficient vacuum extraction system only starts during the plasticizing process, consuming less energy without affecting the extraction result.

Compared with the conventional vented screw, YIZUMI' s drying-free technology offers the advantages of low energy consumption, small footprint of vacuum equipment, stable plasticizing process, easier and safer operation and maintenance.

### Highlight ②: High-efficiency hydraulic mold changing system

YIZUMI' s integrated solution adopts a hydraulic clamping system, making the operation easy and simple. It takes only one click to load or unload the mold immediately, allowing quick mold change, less labor requirement, and safe operation.





**Post-processing automation**

**Highlight ①: Safety fence**

The safety fence is interconnected with the automated production system. All equipment becomes non-operational when the fence door is open to ensure the safety of operating personnel!

**Highlight ②: Automated inserts conveying, inserting, and finished product extraction**

Trolley wheels need to have bearings embedded during the process. YIZUMI's integrated solution allows a quick and easy change of materials: the robot will extract four finished trolley wheels and place them in the finished goods storage area. Then, it will place the 4 bearings with tooling preheated to 80~90°C into the mold. The trolley wheel extraction and bearing embedding are completed in one step, resulting in shorter placement time and unmanned operation.



**Highlight ③: In-mold visual monitoring system**

The in-mold visual monitoring system is interconnected with the injection molding machine and the robot. It will check during each molding cycle whether the product is completely extracted and the bearing is inserted in place. It also protects molds to ensure production safety.

**Highlight ④: Automated warehousing of finished products**

In this solution, YIZUMI has achieved automation in processes such as product placement, packing, storage container stacking and conveying, and material delivery by AGV.

The SCARA robot will pick up the trolley wheels from the finished goods storage group, place them in the empty storage container on the stacker, and fill the containers in turn. The container will be moved down by one level when it is full, while an empty container is moved up by one level to be filled. The cycle keeps running till the preset number of containers is full. An AGV will then be called automatically to move away the containers with finished goods.

The AGV can automatically transport both empty and full containers. It will transport the empty containers from the dock to the stacker and full containers from the stacker to the dock, realizing unmanned operation in the entire process.

**Highlight ⑤: Intelligent interconnection: 100% traceability of the product process**

Supported by the YIMES intelligent execution system, YIZUMI's integrated solution

provides customers with high-quality production control through various professional tools such as PO management, production management, quality management, process management, production monitoring, energy consumption management, and mold management, allowing customers to have standards before production, proper control during production, and traceability after production. Currently, it has achieved 100% system management of PO progress, and 100% monitoring, early warning, and traceability on product process.

**Highlight ⑥: Create a digital twin through AR technology**

The integrated solution for automated trolley wheels production allows customers to have a clear view of the operation process in the injection molding machine, the robot, the centralized compact feeding system, the auxiliary equipment, and the post-processing automation through the construction of a digital twin and online 3D simulation modeling.

In the real-time digital twin mode, users can not only observe the operation on an app, but also check the pressure, oil temperature, flow rate and other real-time parameters of the equipment at any time.



■ Automated warehousing of finished products

“The integrated solution for automated injection molding production starts from the consistency of raw materials and processes”

In the automation field of injection molding production, the real pain point for customers is the lack of standards and data for raw materials and processes. Some customers have no standards for raw materials and change them frequently. The production process and product inspection rely heavily on the personal experience of the operators. Although the product may ultimately be successfully produced, the repeatability, yield, and capacity of the production cannot be effectively guaranteed.

These issues will take a toll on the operation of the entire production system. A stable automated production is warranted only when high-level stability among each production section and great consistency between raw materials and processes are kept.

Taking into consideration of customer value, YIZUMI provided the integrated solution for injection molding production automation and worked closely with customers to tackle the issues. By quantifying the process parameters of raw materials, processes, and products, YIZUMI achieved the standardization and digitization of the entire production process. Based on that, YIZUMI tailor-made the non-standard equipment for customers and is now able to provide an integrated solution.

More importantly, in addition to offering the injection molding machine with automation equipment, the injection molding production automation solution has realized production standardization and digitization, allowing every step of the production to have a standardized and stable process, and information to have an effective transmission. Empowered by the system integration capability, YIZUMI is now offering integrated solutions covering raw material,

process, mold, injection molding machine, automation unit, and industrial interconnection and has found applications in medical, home appliances, and 3C industries.

—Wu Xunyang, Automation Project Manager of YIZUMI Technology Center



■ Trolley wheel automatic production integrated solution



# W1 Series —Tailor-made for the Deep-cavity Products

YIZUMI self-developed product, covering 530T-1100T models



The well-known Malaysia plastic pail manufacturer—TACOPLAST INDUSTRIES SDN. BHD. recently introduced a unit of YIZUMI W1 Series special machine UN680W1, which has been successfully put into the production of 18-liter deep-cavity plastic pails.

Founded in 2021, TACOPLAST mainly engages in the manufacture of high-quality paint pail and other products for the paint and food industry, which covers the Southeast Asian and Indian markets.

Facing fierce market competition, TACOPLAST has been seeking more efficient and automated production solutions and reliable equipment with high speed, higher precision, and stability.

YIZUMI W1 series machine is specifically designed for deep-cavity products. It applied a new kind of clamping structure —an outward toggle, which will turn to the outside during mold opening. Compared with the inward toggle machine, the W1 series machine can directly transmit the clamping force to the mold and therefore minimize the mold deformation. Besides, the opening stroke and the machine application range can be larger, not limited to the in-mold space, especially suitable for the production of deep-cavity products such as trash bins, barrels, chemical buckets, plastic stools, and the outer drums of washing machines.



- ◆ The stress centralized on the two platens, which minimizes the platen deformation, improves the effective clamping force, and reduces the flash;
- ◆ The large opening stroke supports the wide application range of the machine;
- ◆ Stable mold opening and closing, fast speed, short cycle time, efficiency improvement;
- ◆ Improve the utilization rate of clamping force, save energy and reduce the wear and tear of the machine;



YIZUMI self-developed W1 series machine for deep-cavity product production is available with clamping forces from 530T to 1100T. Its structural parts including clamping structure with extra-long mold opening stroke, platen with high rigidity and small bending moment, and split-type ejection mechanism with low inertia, have obtained intellectual property protection. The standard machine equipment includes clamping structure with long mold opening stroke, servo pump, proportional valve for mold opening and closing, safety valve, safety module, KEBA control system, etc., which also can be adopted in in-mold labeling as well as robot removing as required, further providing higher cost performance.



The head of the TACOPLAST said: “The clamping structure with long opening stroke and the electric storage of YIZUMI UN680W1 can achieve shorter cycle time. The current cycle time stabilizes in 23 s, 20% shorter than the original cycle time. We believe that the cycle time can at least reduce to 18 seconds if using a new mold, and the production efficiency will be significantly increased.”

“We expect to keep close cooperation with YIZUMI and WY MACHINERY. As our agency

company, WY MACHINERY’ s after-sales service team can solve our problems in time with excellent attitude and standard. We also hope YIZUMI continues to provide us a better price and higher cost-effective solutions.”



# YIZUMI Provides 8-cavity IML Silicone Cartridge Solution



In the field of packaging container production, manufacturers' requirements for product quality and efficiency have been rising. They now need more efficient and cost-effective integrated solutions that can help them to reduce costs, achieve high-quality decorative effects, and get advantages in market competition. As a type of packaging container, the processing production of silicone cartridge is also moving toward this direction.

The most recent case from an overseas customer requires solutions of high product quality and higher cost effectiveness. To meet customers' requirements, YIZUMI tailor-made an integrated solution, which integrates with IML automated labeling system and auxiliaries on the basis of PAC350 high speed injection molding machine equipped with eight-cavity hot runner mold, realizes automated production of silicone cartridge with 20s cycle time.

The molding of deep-cavity Silicone Cartridge of 225mm height that employs low-fluidity HDPE material is not easy. According to the product specifications and in-mold labeling process requirements, YIZUMI PAC350 high-speed injection molding machine is configured with the high-performance mixing screw to feed the large volume of plastics in eight-cavity mold(48g each).



In addition, because silicone liquid is squeezed out by pistons, it has a very high requirement for coaxiality and verticality. Otherwise, it can result in stuck piston, plastic leakage, or other quality problems. YIZUMI adopted the independent cavity design, sliding block and needle-valve hot runner system in the mold to ensure high-quality and high-efficient production.



To achieve high-quality appearance effect, YIZUMI adopted the high-precision labeling robot to accurately pick and deliver the labels and place them into the mold cavities. The finished product will be dropped onto the conveyor belt at the bottom after mold opening, no need of extraction robots.



Supported by the high-speed injection molding machine, mold and labeling system, YIZUMI's 8-cavity IML silicone cartridge solution can achieve an automated production with a cycle time of 20s, fulfilling customer requirements for efficient production, high quality, and lower cost.

Product: Silicone Cartridge  
 Material: HDPE  
 Part size:  $\phi 47 \times 225 \text{mm}$   
 Part weight: 48gx8  
 Number of cavities: 8  
 Cycle time: 20s



# Worry about the Clamping Force Issue? Try This New Function...

Do these problems frequently occur during your injection molding process?

Having no idea about the appropriate clamping force of a mold?

Unable to cope with the fluctuation of product quality due to the clamping force changes in production?

Cannot judge whether the flash is caused by inadequate clamping force or mold defect?

Have to repeatedly adjust the clamping force and venting slot because of poor venting and flash when changing the mold?

Shall shortened mold life be attributed to bad mold quality or improper operation?

.....



The clamping force of injection molding machines plays an essential role in plastic parts production. However, the IMM operators often get stuck on some problems in their daily work, no matter experienced operators or green hands. The SCFM System (Smart Clamping Force Management System) was born under this circumstance. As a new function of YIZUMI electric injection molding machines, the system focusing on the actual requirements of operators is able to intelligently recommend the most appropriate clamping force.

## What is the SCFM system?

In short, it is a system that can automatically adjust the clamping force according to the set figure based on the automatic mode. It has a variety of functions, including real-time measurement, smart recommendation, adjusting without stopping the machine, automatic holding, etc., which enable the operators to control the injection molding machine and set appropriate clamping force in a quick and convenient way.



## [Q&A]



**Q: How to check the real-time clamping force of the injection molding machine?**

A: Real-time value of the clamping force is available on the computer interfaces through the new SCFM system equipped on YIZUMI electric injection machine.



**Q: Why does the clamping force change? How to ensure its stability?**

A: During the machine operation, the clamping force may be affected by the mold temperature, water temperature, injection molding process, plastic viscosity, etc. For example, influenced by these factors in a practical operation, 100T of clamping force probably turns into 110T or 90T.

The unstable clamping force also results in the quality deviation of final products, like product weight and wall thickness. Thus, a stable clamping force is necessary for the stability of product size and weight.

This problem can be solved by the SCFM system on YIZUMI electric injection molding machine. Its automatic holding function can automatically adjust the clamping force to ensure the same value for an extended period when the clamping force changes during operation.

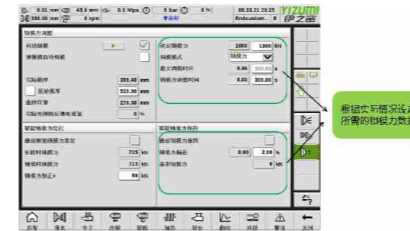

causes flash and considerably decreases the yield. We also found that some of our customers frequently used excessive clamping force, which isn't a good habit. Because an excessive clamping force is proved to be a kind of "abuse" to the equipment that will increase wear to the molds and machines, shorten their service life, be unfavorable for cavity exhaust as well, resulting in trapped gas, burn marks, and energy waste.



■ The SCFM maintains stable clamping force and ensures product yield

**Q: How to set the optimal clamping force?**

Theoretically, the clamping force should be capable of overcoming the cavity pressure for stable and qualified production and is expected to be as small as possible after determining the injection process parameters. The SCFM system on YIZUMI electric injection molding machine will select the optimal clamping force and then recommend it to the customers by real-time monitoring. The optimal value perhaps is a little smaller than the original value, but more appropriate, while avoiding the problems caused by excessive clamping force. To some extent, we can say the system has self-learning ability that enables no matter experienced operators or green hands to find out the optimal clamping force, achieving rapid and stable production and reducing enterprise cost.

**Q: What if the worn mold needs a larger clamping force to avoid the flash?**

A: The SCFM system on YIZUMI electric injection molding machine can modify the clamping force to the optimal value to adapt to the actual production when the mold is

worn out or imprecise. Without stopping the machine, operators just need to input the clamping force value on the computer screen and modification can be realized within several trials, shortening the operation time. If the modification exceeds the rated range, the machine will remind the operators to improve the mold.



**Q: What value can it bring to customers?**

A: Using the SCFM system on YIZUMI electric injection molding machine to identify the optimal clamping force makes production scheduling more reasonable and operating costs more competitive; Reasonable clamping force can prolong the service life of molds and machines, and reduce the energy consumption and maintenance cost; Product quality stability can be improved to a certain extent; With the statistical analysis of monitoring data, the fault diagnosis is more clear and accurate. When there is a clamping problem, you can quickly determine whether the clamping force is insufficient or the mold accuracy is reduced. It is also easy to determine even if the mold is used to other injection molding equipment.



# YIZUMI Factory Outlet

## New service standard for the industry

YIZUMI Factory Outlet (YFO), as a future-oriented global service strategy, ensures the fast response and high controllability of services. For customers, we not only guarantee their safe production, but reduce the equipment shutdown risk to a large extent so as to improve their productivity.

"From pre-sale consulting to onsite installment and commissioning, from after-sale tour-inspection to part delivery and customer training, each of us has the experience of more than 300 cases to enhance your confidence in our services." said an experienced YFO engineer.

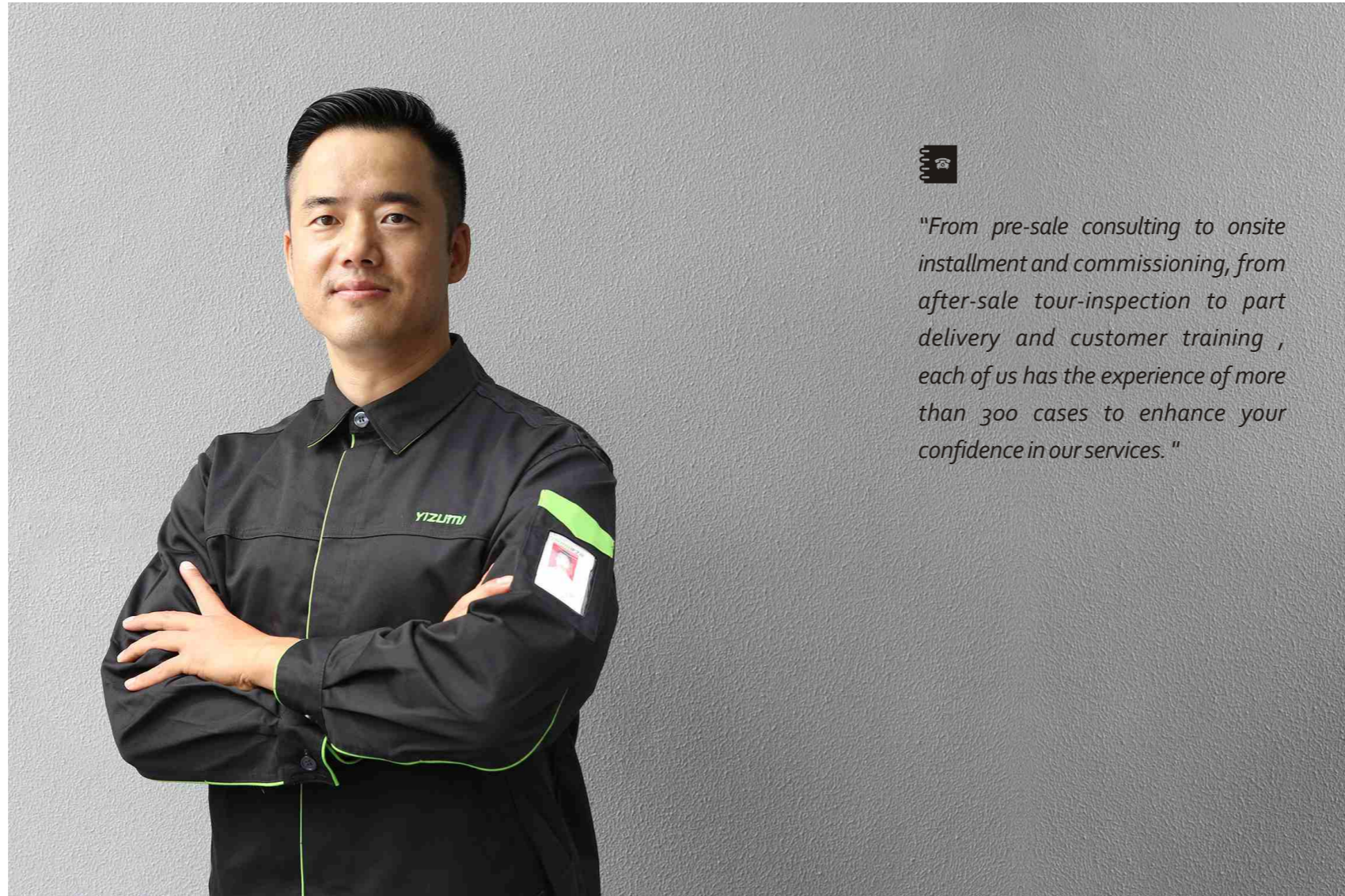

*"From pre-sale consulting to onsite installment and commissioning, from after-sale tour-inspection to part delivery and customer training, each of us has the experience of more than 300 cases to enhance your confidence in our services."*



### The worldwide part supply network ensures smooth, prompt and accurate part distribution

- China** 35 part centers and warehouses
- Abroad** 14 part centers in Indonesia, Malaysia, South Korea, Vietnam, Russia, Spain, France, Turkey, Israel, Poland, America, Iran, India and Brazil, etc.



### Overseas service

**Long-distance support:** when there are complicated problems in the operation of machine, engineers of the headquarters will provide long-distance technological support for overseas agents or customers to solve the problems in time.

**Pre-sales support:** we have a team specialized in pre-sales technological support, and they will collect molding cases so as to provide solutions for overseas customers efficiently.

**Communication:** over 90% of our engineers can speak fluent English, which is conducive to solving customers' problems.



**365/24**

The service hotline is available 24 hours a day, 7 days a week, and 365 days per year with over 100 maintenance experts on line all over the world.

**59**

The YFO covers 35 Chinese cities and 24 overseas places.

**35,000**

The YFO team has provided services for about 35,000 machines.

**10**

More than half of the YFO engineers have at least ten years' experience.

**5,000m<sup>2</sup>**

With a total area of 5,000 m<sup>2</sup>, the spare part storage system covers 35 Chinese warehouses and 14 overseas part centers.

# Six YFO Commitments



|  |   |
|--|---|
| <p><b>Pre-sales support:</b></p> <ul style="list-style-type: none"> <li>1) customized solutions to machine selection</li> <li>2) professional advice on plant layout</li> <li>3) technology solutions before manufacturing</li> </ul>  | <p><b>Fast distribution of spare parts</b></p> <ul style="list-style-type: none"> <li>1) The same-day delivery rate reaches 97%</li> <li>2) There are more than 7,000 different spare parts in storage with a total value of over RMB 10,000,000.</li> <li>3) The key spare parts are produced by Yizumi or imported and some can be used in the machine made in 2002.</li> <li>4) Every quarter the Chinese headquarters will replenish the spare part warehouses of overseas agents so as to satisfy the needs of customers.</li> </ul> |
| <p><b>Focus on the improvement of customer satisfaction</b></p> <ul style="list-style-type: none"> <li>1) Promote fast response to reduce the machine shutdown risk to a large extent</li> <li>2) Each service center will pay regular return visits to customers and conduct survey on customer satisfaction in order to understand their need promptly.</li> </ul> | <p><b>Preventive maintenance</b></p> <p>Onsite inspections are organized regularly and resident service will be provided in key markets and customers' to ensure prompt service.</p>  |
| <p><b>High-standrad training and practice</b></p> <ul style="list-style-type: none"> <li>1) The service inspection and trainings of agents will be organized at least once a year.</li> <li>2) Onsite commissioning and customer training service will be provided for Large machines (1400T and above)</li> </ul>   | <p><b>Lifelong service</b></p> <p>The lifelong maintenance are guaranteed beside a 13 months' warranty on the whole system</p>  |

## YIZUMI e-service

Delivering a real-time service system for its clients

Through YIZUMI e-service, you can have a full-day, online support, mobile and rapid remote repair and maintenance as well. Regardless of where you are, it can deliver a rapid, convenient, online after-sales service, ensuring the equipment to be maintained in the best condition for the long term.

- Rapid
- Reliable
- Effective
- Visual
- Recordable
- Can be evaluated
- Cost effective

YIZUMI e-service can deliver the followings to you .....



Mobile Operation: Smart Phone/Tablet/PC Multiplatform available.

Download the APP, enter equipment serial number /scan equipment QR code and the registration is completed.



IOS

Android