

A6

UN1200-1850A6

A6 SERIES STANDARD HIGH-END SERVO
INJECTION MOLDING MACHINE

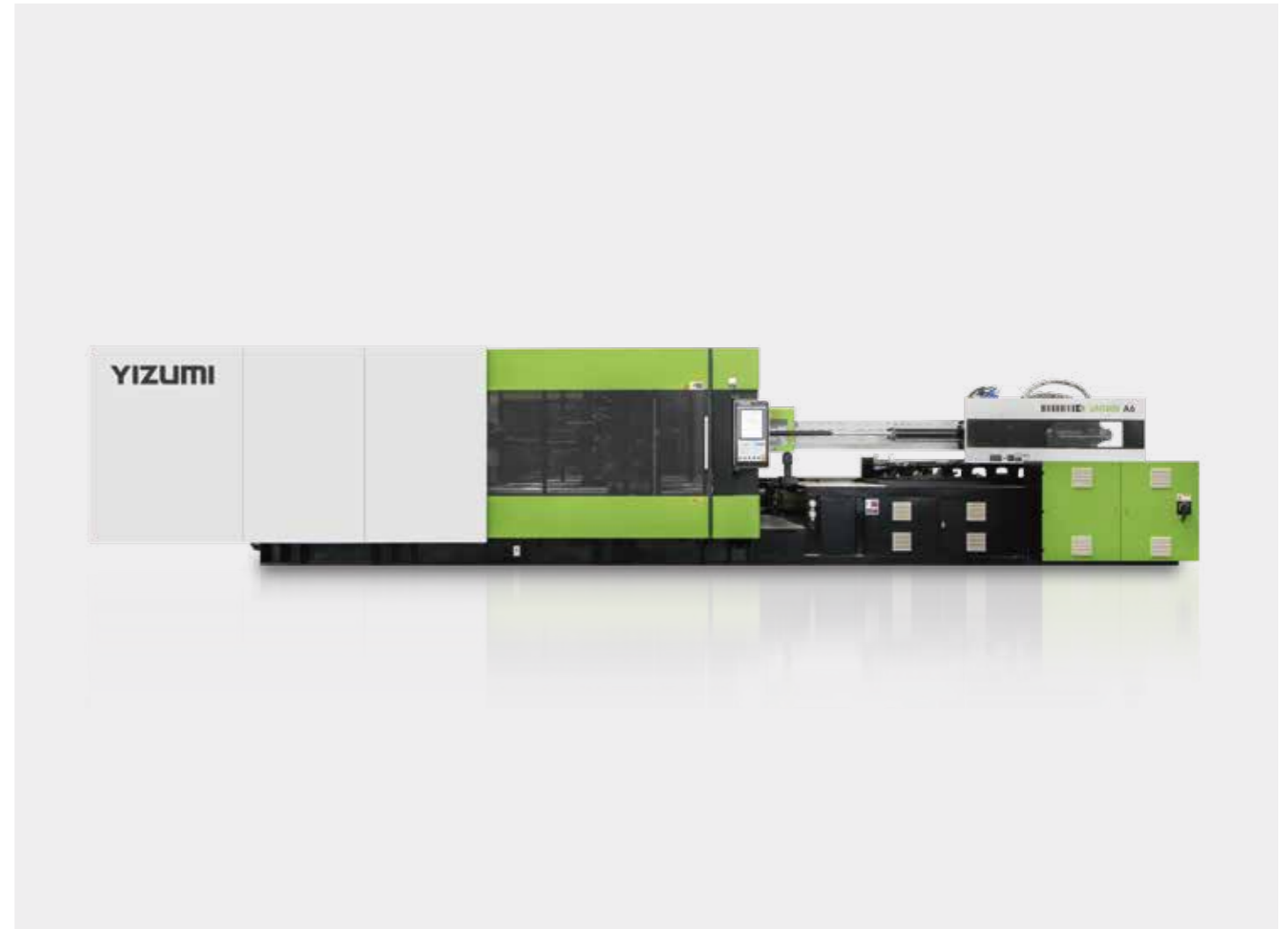

Yizumi Precision Molding Technology Co., Ltd.

Address: No.12 Shunchang Road, Shunde, Foshan, Guangdong 528300, China
TEL: 86-757-2921 9764 86-757-2921 9001(overseas) Email: imm@yizumi.com
www.yizumi.com

[DISCLAIMER]

[1] YIZUMI reserves the right to modify the product description in the catalogue. Specification might be changed without prior notice.

[2] The picture in the catalogue is for reference only. The real object should be considered as final.

[3] The data in the catalogue is obtained from internal testing in YIZUMI laboratory.

Please refer to the actual machine for the final data. YIZUMI reserves the right of final interpretation upon disputes and ambiguities.



THINK TECH FORWARD

A6

PRODUCT DETAILS

PRODUCT DETAILS

Reinvention of A6 large tonnage series

Since the successful introduction of the A5 large tonnage series to the market, its core customer value — Reliability and Stability — has been widely recognized and validated by customers. In response to this trend, YIZUMI's A6 IPD project team made a comprehensive upgrade to the A6 large tonnage series with a focus on its stability, reliability, and plasticizing requirement while retaining the advantages of the product lines of the entire series, which is highly consistent with the needs of customers and the industrial "pain points".

Customer Value Propositions

Five Value Propositions

- Wide range of application
- Precise and stable
- High-efficiency and energy-saving
- Reliable and durable
- User-friendly

In order to ensure the implementation of the core value of "reliability and stability" among the A6 large tonnage machine family, we have refined and quantified the factors in terms of achieving improvement:

With the normal process, the repeatability of product weight is up to 3‰.

<0.26

Platen parallelism (after load) <0.26mm (UN1200A6)

±3%

Force deviation of tie bar <±3%

<0.6

Platen parallelism (mold opening to 100mm) <0.6mm (UN1200A6)

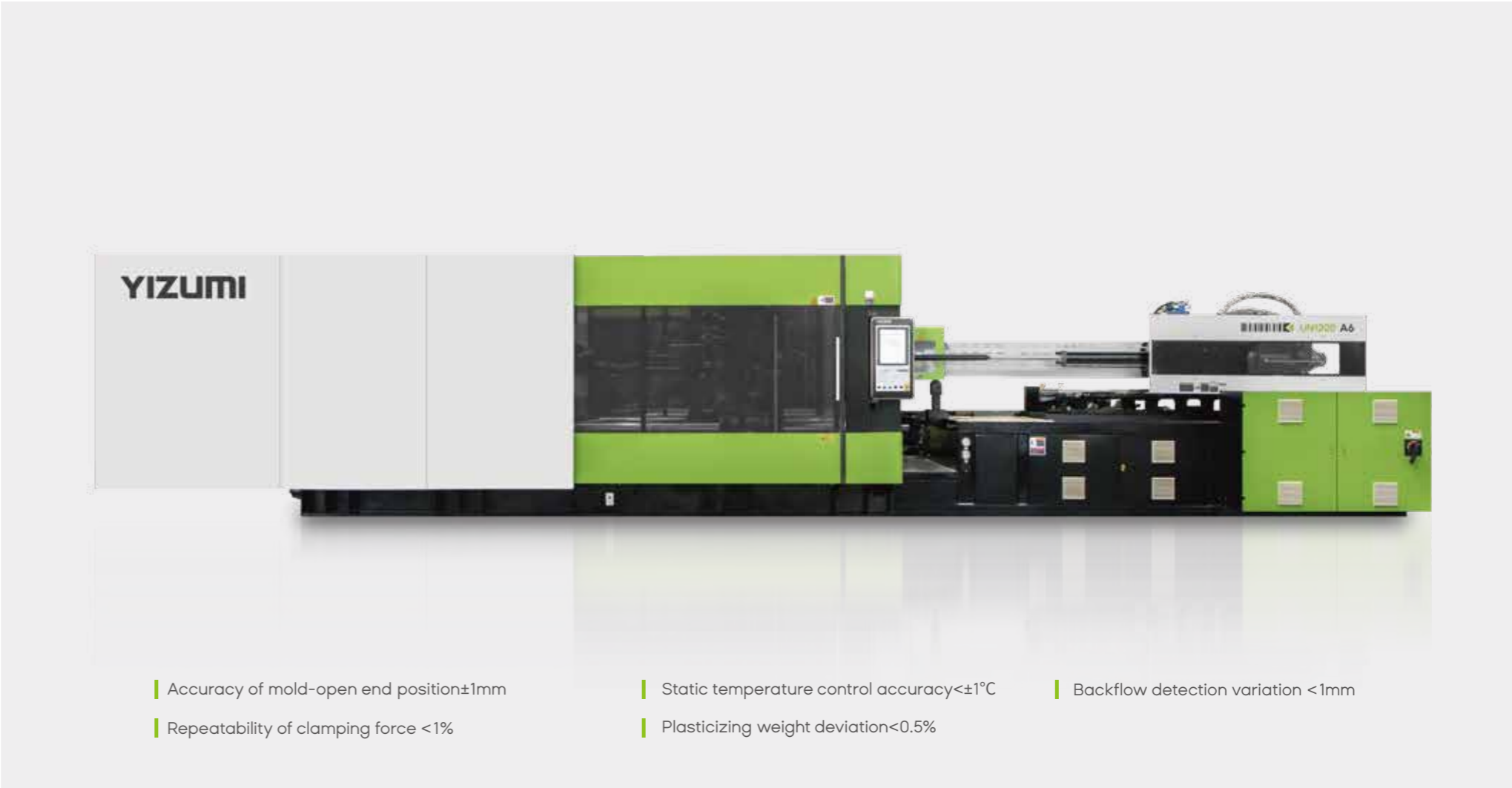

- Accuracy of mold-open end position ±1mm
- Static temperature control accuracy <±1°C
- Backflow detection variation <1mm
- Repeatability of clamping force <1%
- Plasticizing weight deviation <0.5%

※ The Data above were acquired by testing in the factory, only for your reference. The specific data please accord to the actual equipment

Clamping Unit

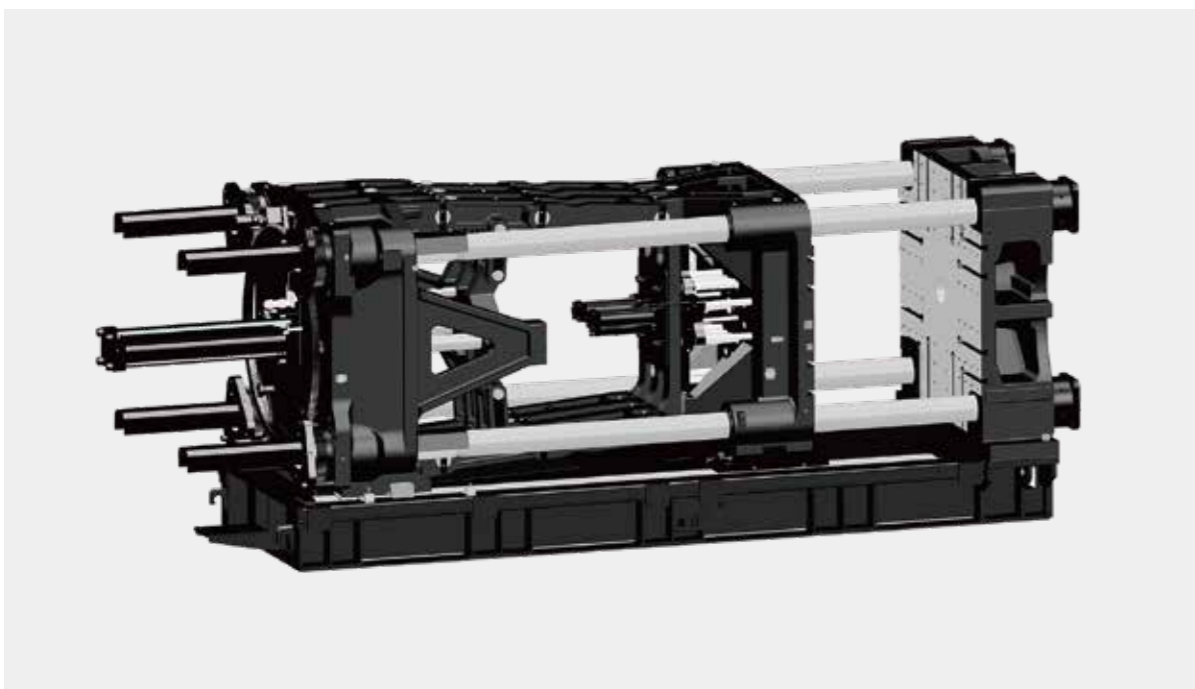

Mechanical structure of clamping unit — stable, high-rigidity

The platen structure is designed with European style and fully optimized parameters and force distribution. High-rigidity materials and manufacturing processes for base frame ensure the machine is strong, stable and reliable.

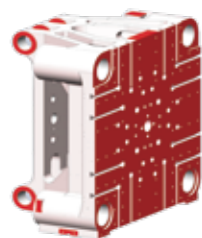

High-rigidity T-slot platen

- ▶ Full range of highly-rigid platen greatly improve the overall rigidity of the clamping unit;
- ▶ The series is equipped with T-slotted platen to facilitate mold loading/ unloading, reduce the rate of wear on screw hole threads after prolonged use and extend the useful life of platens.

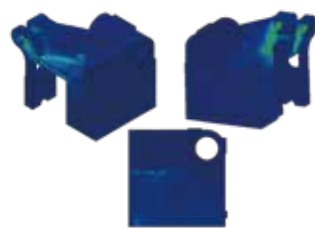

Uniform-stress clamping technology

- ▶ Uniform distribution of clamping force, less platen deformation;
- ▶ Lower clamping force is applicable to produce the same part without flash, protecting platen and mold.

Compulsory ejector return

- ▶ Standard ejector forced reset feature to fulfill the forced reset requirement for certain special molds and expand mold applications.



Extended movable platen support

- ▶ The movable platen is equipped with front-loading sliding supports. The center of gravity of support moves forwards to the mold mounting surface, preventing the platen from tilting. Machine still operates steadily when it is loaded with heavy molds.



Extended ejector guiding platen design

- ▶ Ejector guiding extended, effectively avoiding ejector plate tilting and improving stability of ejection;
- ▶ Uniform distribution of ejector force, precise ejection position with better ejection performance.

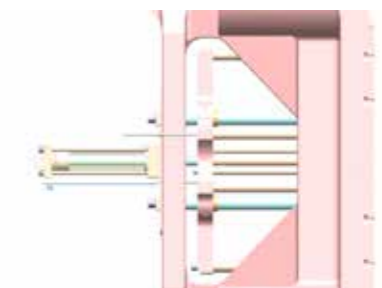

Injection Unit

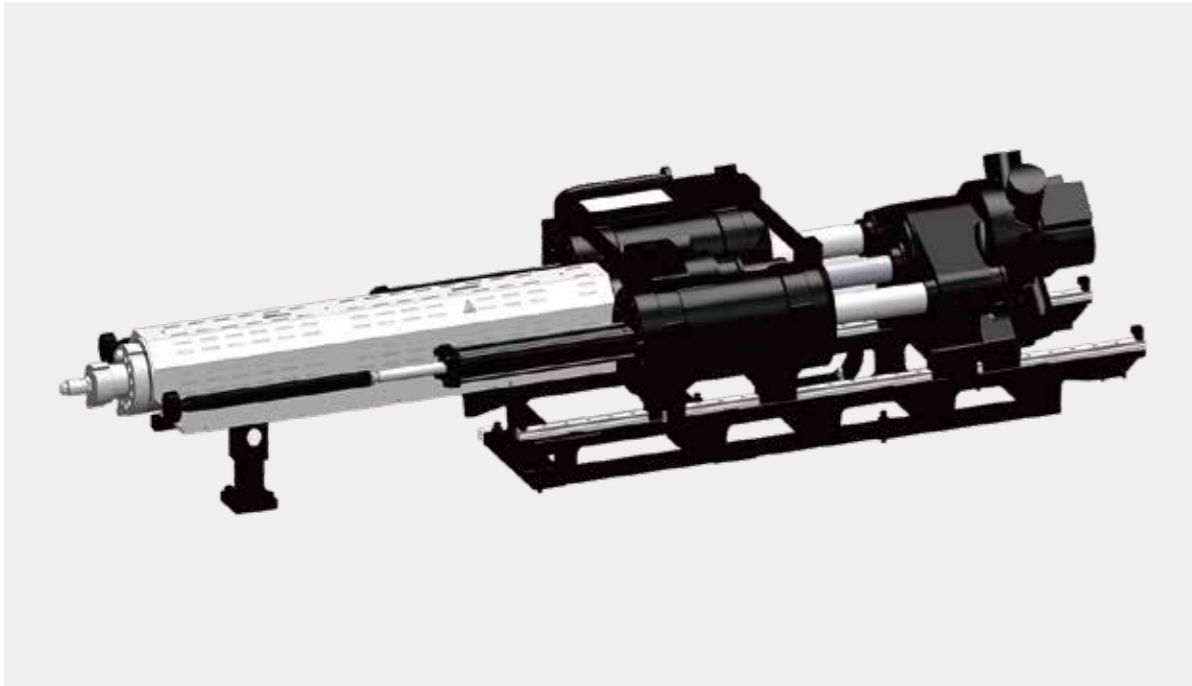

Mechanical structure of injection unit—stable, less friction

Optimized injection structure design improves rigidity of injection unit;

Reduce all frictional resistance during injection molding process enhance the stability & precision of injection.



Proportional plasticizing back pressure control

- ▶ Proportional back pressure facilitates accurate control by industrial computer and enhances the stability of injection.

Low friction oil seal inside injection cylinder

- ▶ Injection cylinder adopts low friction oil seal design, fully reducing injection friction and ensuring longer service life.

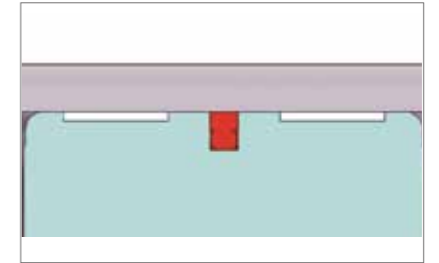

Integrated linear guide rail support

- ▶ Integrated linear guide rail, horizontal double-carriage design and double-cylinder injection are adopted to ensure reliable and stable injection.
- ▶ Integrated linear guide rail support reduces the friction between injection unit and linear guide rail and enhances production repeatability.



Optimized plasticizing screw

- ▶ The plasticizing efficiency is optimized by 10%-30% and the quality of plasticizing and color mixing is improved as well.
- ▶ The useful life of the screw increases by 1-2 times with a standardized C-grade alloy screw.



Hydraulic System

YIZUMI's new-generation energy-saving servo technology — reliability and durability, high-efficiency and energy saving, low noise.

Since 2005, YIZUMI's engineers have been conducting in-depth studies on the energy-saving servo system and gained a perfect command of the application technology. The new generation servo system has made a comprehensive upgrade in many aspects from the internal structure and magnet requirements of motors, oil pumps, and the development of the drive software, offering stability, reliability, durability, energy efficiency, high productivity, low noise, and other optimized performance. The entire series meet the Grade-1 energy rating stipulated in GB/T30200-2013 "Test Method for Energy Consumption of Rubber and Plastics Injection Molding Machines."

Low noise — For the production of the same product under the same working conditions, the new generation servo system adopts a high-efficiency and low-noise gear pump to protect the hearing.

Strong power — The servo system has sufficient power and strong overload capacity, for example, A6 Series IMM can raise no overload alarm at maximum speed and under maximum pressure for 5 minutes in a test

New-generation servo system

With years of market validation, we offer features such as better combined configuration, robust and reliable system performance, high energy efficiency, low-noise, strong power, and fast response.

Improve motor cooling effect, enhance overload capacity, and reduce motor noise.



High-performance oil-cooled servo motor

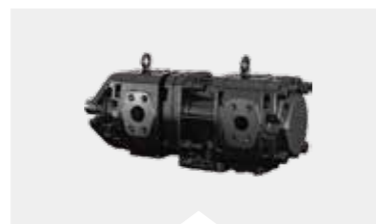

High-pressure duplex gear pump



Servo drive

Electrical System

High-precision control system — More accurate control on system pressure, flow, position and temperature to allow better stability of product quality and machine performance.

Upgraded KEBA 15 inch touchscreen system

- ▶ Expandable with multiple modules including AO, AI, DO, DI, and TM to meet more requirements;
- ▶ Real-time monitoring of signals from machine equipped sensors to coordinate corresponding movements for higher operating safety;
- ▶ Support common RS232/485 communication interface, CANOPEN, Ethernet, temperature compensation sensor, and USB port..



Proportional hydraulic mold opening/closing circuit

- ▶ High-response closed-loop proportional directional valve control is used in mold opening/closing to improve the accuracy of opening position, smoothness of moving, and response speed.



Weldless flared hydraulic hose design

- ▶ Ensure no oil leaks due to cracked weld despite long-term use.

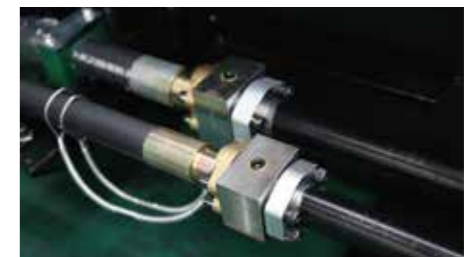

Low oil level alarm

- ▶ Automatic low oil level alarm function prevents gas from being sucked in due to low oil level, avoiding consequent instability of hydraulic circuit



Specifications of UN1200-1850A6

DESCRIPTION	UNIT	UN1200A6				UN1400A6				UN1600A6				UN1850A6			
Injection unit model		IU9015				IU10470				IU14470				IU14470			
International specification		9015/12000				10470/14000				14472/16000				14472/18500			
INJECTION UNIT										INJECTION UNIT							
Shot volume	cm ³	4319.7	5038.5	5812.6	6749.5	5221.7	6023.9	6994.9	8158.9	7976.7	9304.0	10733.4	12265.0	7976.7	9304.0	10733.4	12265.0
Shot weight	g	3974.1	4635.4	5347.6	6209.5	4804.0	5542.0	6435.4	7506.2	7338.6	8559.7	9874.8	11283.8	7338.6	8559.7	9874.8	11283.8
	oz	140.2	163.5	188.6	219.0	169.5	195.5	227.0	264.8	258.9	301.9	348.3	398.0	258.9	301.9	348.3	398.0
Screw diameter	mm	100	108	116	125	108	116	125	135	125	135	145	155	125	135	145	155
Injection pressure	MPa	208.9	179.1	155.2	133.7	200.5	173.8	149.7	128.3	181.4	155.6	134.8	118.0	181.4	155.6	134.8	118.0
Injection rate	g/s	686	801	924	1073	784	904	1050	1225	1016	1185	1367	1562	1016	1185	1367	1562
Screw L:D ratio		21.6:1	22:1	21.6:1	20:1	23.6:1	22:1	21.6:1	20:1	23.6:1	22:1	21.4:1	20:1	23.6:1	22:1	21.4:1	20:1
Max. injection speed	mm/s	95				93				90				90			
Screw stroke	mm	550				570				650				650			
Screw speed (stepless)	r/min	0-126		0-113		0-120		0-113		0-114		0-103		0-114		0-103	
CLAMPING UNIT										CLAMPING UNIT							
Clamping force	kN	12000				14000				16000				18500			
Opening stroke	mm	1310				1500				1600				1650			
Space between tie bars (W×H)	mm×mm	1250x1250				1450x1350				1550x1430				1650x1500			
Max. daylight	mm	2560				2900				3150				3250			
Mold thickness (Min.Max.)	mm	500-1250				600-1400				650-1550				750-1600			
Ejector stroke	mm	320				380				400				400			
Ejector number		29				29				29				33			
Ejector force	kN	274				303				303				430			
POWER UNIT										POWER UNIT							
Max. system pressure	MPa	17.5				17.5				17.5				17.5			
Pump motor power	kW	98.4				108.9				138.2				138.2			
Heater power	kW	59/66.7				66.54/70.6				87.9				87.9			
Number of temp control zones		8				8				8				8			
GENERAL UNIT										GENERAL UNIT							
Dry cycle time	s	7.7				9				11.1				12			
Oil tank capacity	L	1045				1195				1245				1260			
Machine dimensions (L×W×H)	m×m×m	12.3*2.86*2.99				13.52*3.11*3.08				14.72*3.28*3.17				15.04*3.41*3.27			
Design weight	kg	55830				/				/				/			

1. Shot weight = barrel sectional area × injection stroke
2. Theoretical shot weight = shot volume × 0.92 (GPPS)
3. Due to improvement, specifications may be changed without prior notice.
4. Please inform us if you need to produce parts made from engineering plastics like PVC, PC, and PMMA or if you have other special requirements.
5. The specification of machine size is based on mid-size barrel. If you need large-size barrel or a special machine model, please refer to YIZUMI actual size.

Platen Dimensions

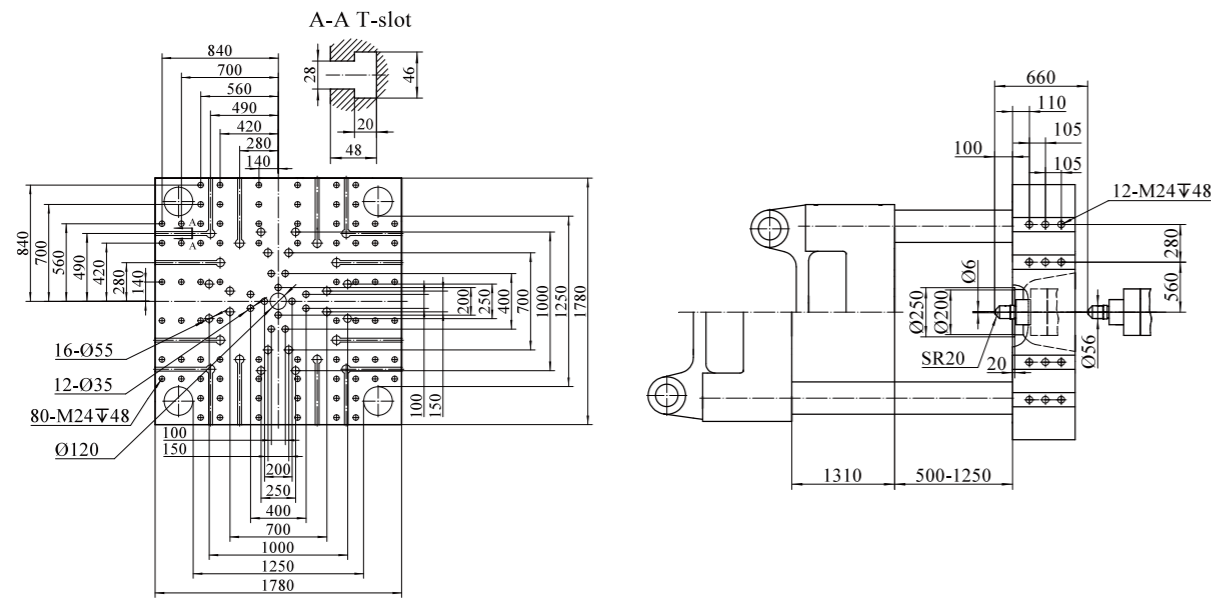

UN1200A6

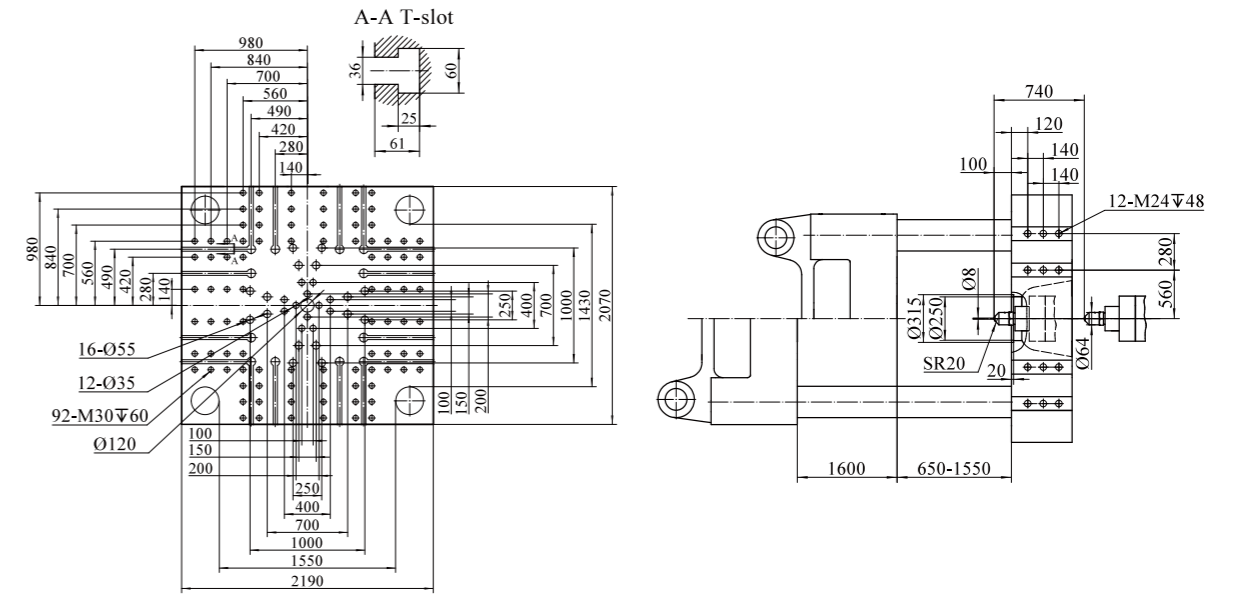

UN1600A6

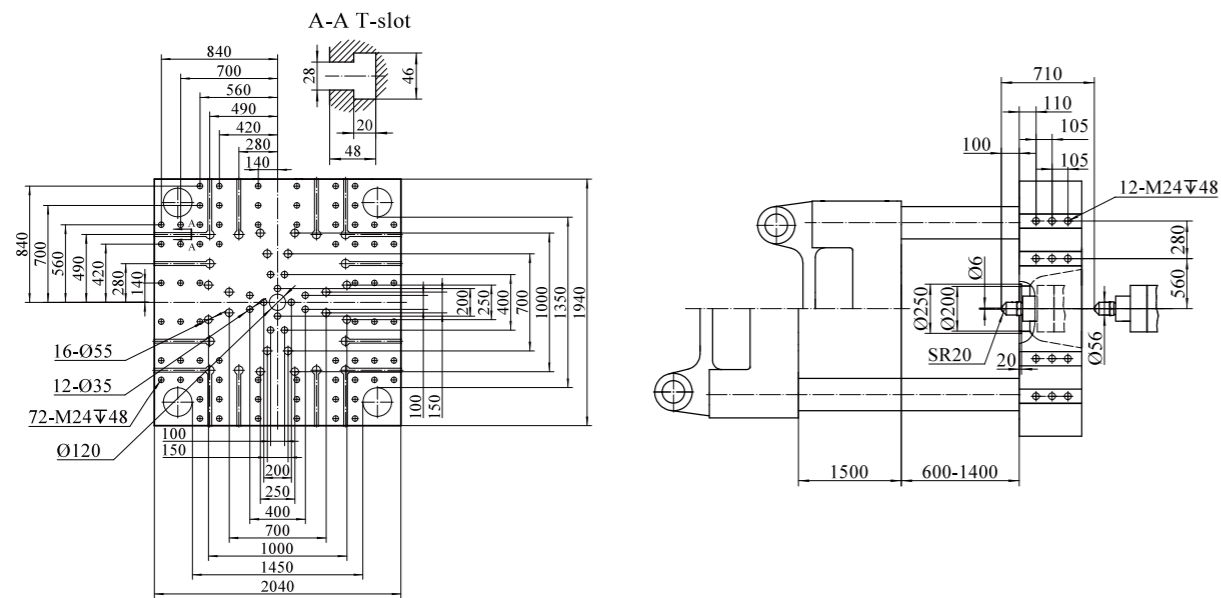

UN1400A6

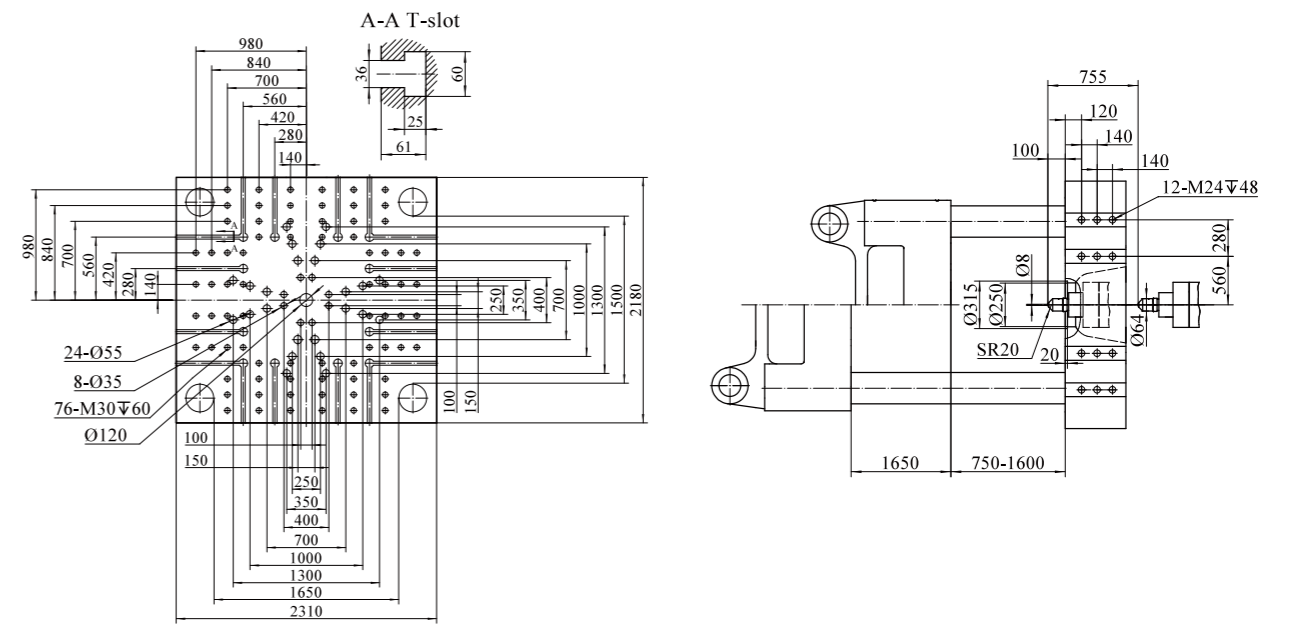

UN1850A6

Machine Dimensions

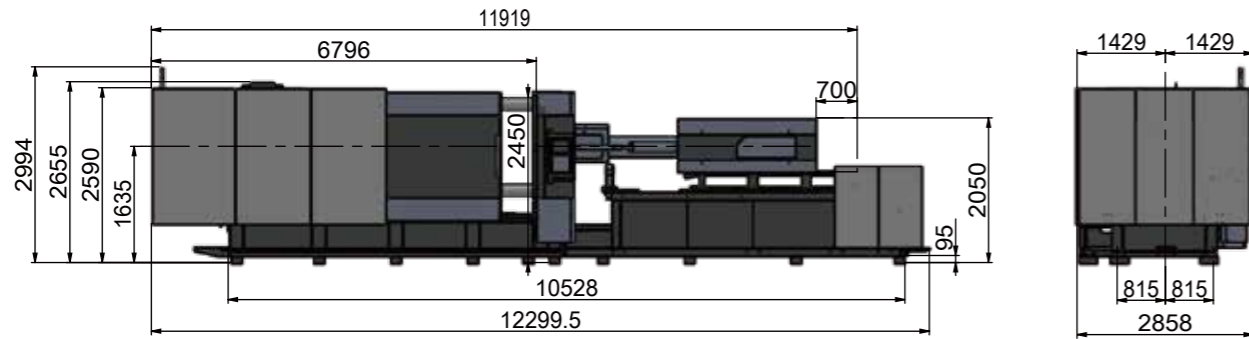

UN1200A6

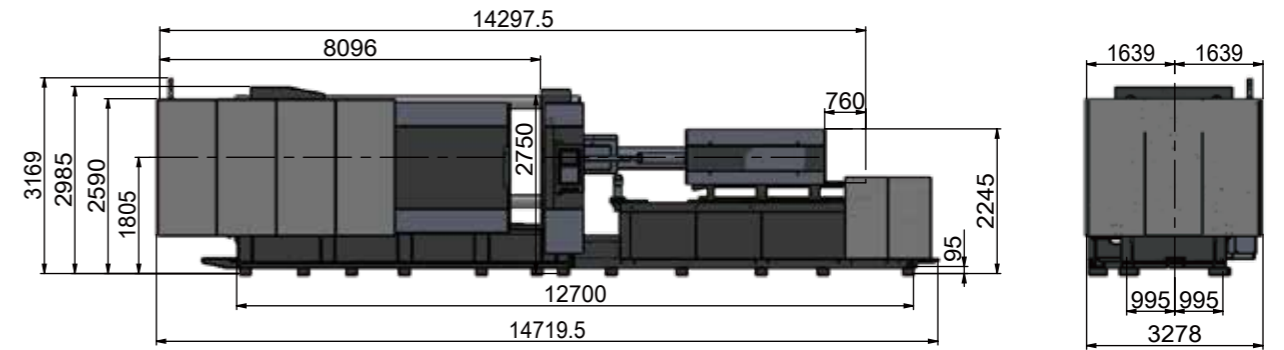

UN1600A6

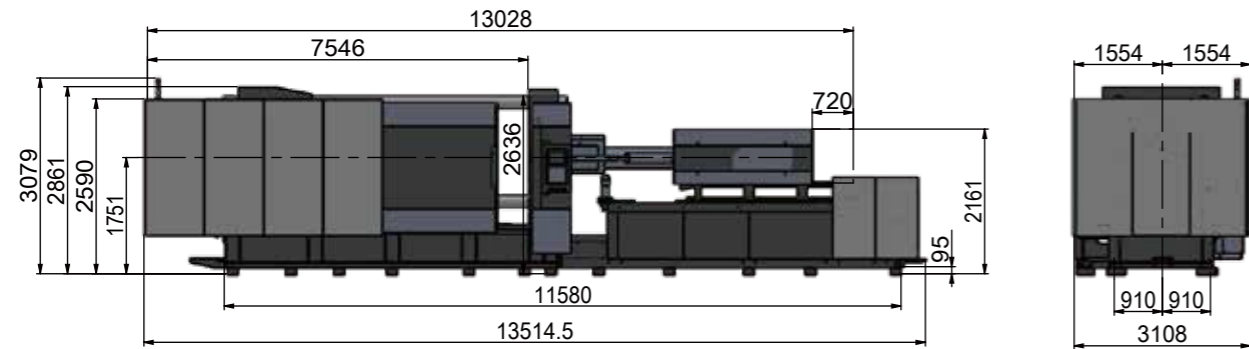

UN1400A6

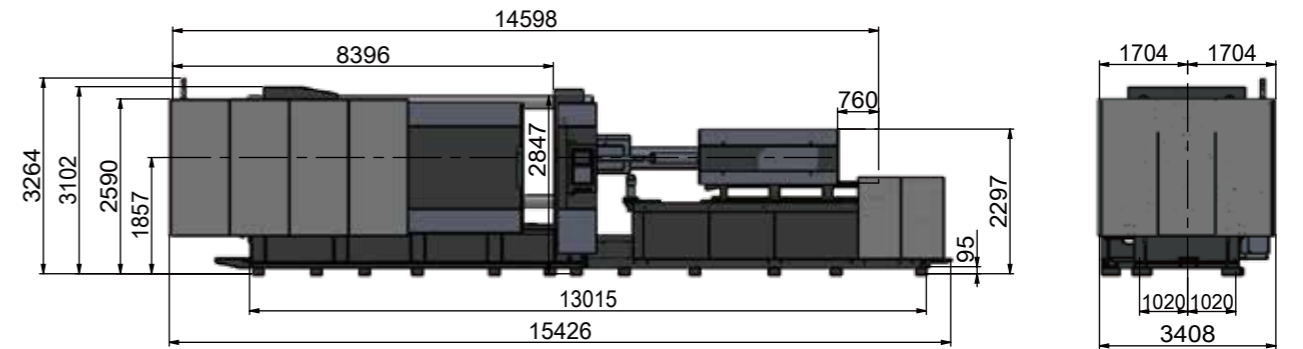

UN1850A6

Standard and Optional Features of UN1200-1850A6

	STANDARD	OPTIONAL
INJECTION UNIT		
One-piece injection unit support with linear guides	●	
Nitrided alloy-steel screw and barrel	●	
Parallel double-cylinder injection system	●	
Low-speed high-torque reinforced hydraulic motor	●	
Double-carriage cylinder	●	
Energy-saving groove design of barrel (patented design)	●	
Multi-stage PID barrel temperature control	●	
Fully-closed heat retaining cover/ nozzle purge guard (with electrical protection)	●	
Cold start protection for screw	●	
Automatic purging	●	
Selectable suck-back before or after plasticizing	●	
Screw speed detection	●	
Precision transducer for injection/ plasticizing stroke control	●	
6-stage injection control (speed, pressure, position)	●	
5-stage holding pressure control (speed, pressure, position)	●	
4-stage storage control (speed, pressure, position)	●	
Digital proportional back pressure	●	
Hard chromeplated screw component		○
Bi-metallic screw component		○
Spring shut-off nozzle		○
Ceramic heater band		○
Barrel air-cooling device		○
Electric plasticizing		○
Extended nozzle		○
Hopper dryer		○
CLAMPING UNIT		
Precision transducer for clamping / ejector stroke control	●	
Clamping platens / toggles made of highly-rigid ductile iron QT500-7A	●	
EUROMAP-based robot mounting holes	●	
Hydraulic mold height adjustment device	●	
Mechanical / electrical/ hydraulic safety devices	●	
Adjustment-free mechanical safety lock rod	●	
Wear-resistant manganese steel supporting tracks for movable platen	●	
Automatic centralized lubrication system	●	
Multiple ejector function settings	●	
Low-pressure mold protection	●	
Platen with T-slots and mounting holes	●	
One-button automatic mold height adjustment	●	
Compulsory ejector-back function	●	
Safety edges for machine gates	●	
Electric safety front gate (synchronous belt)	●	
Increased ejector stroke		○
Special mold mounting hole		○
Mold thermal insulation plate		○
Increased mold thickness		○
Mold lifting device		○
HYDRAULIC SYSTEM		
New-generation servo motor system	●	
High-precision bypass oil filter	●	
Low-noise energy-efficient hydraulic circuit	●	
Brand-name hydraulic valve	●	
Brand-name hydraulic seal	●	
Three sets of hydraulic cores (one for the fixed platen and two for the movable platen)	●	
Three sets of hydraulic core-pull sockets (one for the fixed platen and two for the movable platen)	●	
Two sets of air blowers (one each for the fixed platen and movable platen)	●	
High-speed proportional valve for mold opening and closing	●	
Hydraulic circuit design of mold-open deceleration	●	

	STANDARD	OPTIONAL
HYDRAULIC SYSTEM		
Automatic oil temperature detection and alarm	●	
Cable hose restraint for exposed HP hydraulic hose	●	
Multi-channel cooling water devices with fast connectors	●	
Enlarged oil pump motor connector	●	
Variable displacement pump system		○
Differential fast mold closing device		○
Enlarged oil pump and motor		○
Enlarged plasticizing motor		○
Synchronized ejection, core pulling and plasticizing system		○
High-response servo injection system with accumulator		○
Multiple sets of core puller		○
Hydraulic unscrewing device		○
CONTROL SYSTEM		
Barrel heater protection	●	
Input/output inspection	●	
Automatic heat retaining and automatic heating setting	●	
Time / position / time + position controlled switchover from injection to holding	●	
15" TFT true color display	●	
Storage space for 100 sets of process parameters, USB port for expandable storage	●	
Multiple operating languages	●	
Three-color alarm light	●	
Separate adjustment of motion slope	●	
Robot interface	●	
All transducers, weak-current switches and reversing solenoid valves enclosed by water-proof and rat-proof corrugated pipes	●	
Multi-level password security and key-locked operation panel	●	
Emergency stop buttons for front and rear safety gates	●	
PDP interface	●	
Statistical process control (SPC) interface	●	
Reserved interfaces for air blowers, cores, and ejector backward protection	●	
Four sets of 3-phase power socket (3×32A+16A) (for UN1400-1850A6)	●	
Three sets of 3-phase power socket (2×32A+16A) (for UN1200A6)	●	
Synchronous injection valve open signal	●	
Automatic clamping force adjustment	●	
Hot runner interface		○
Pneumatic sequence valve		○
Interface for electric unscrewing interface		○
Air blow device		○
Working light/ one- or three-color alarm light		○
Single-phase/3-phase power socket		○
Air-assisted injection device		○
Central (networked) monitoring system		○
Protective light grid of safety gates		○
Display of overall energy consumption		○
Change of power supply voltage		○
OTHER		
Operation manual	●	
Leveling pad	●	
A tool kit	●	
Filter	●	
Mold clamp	●	
Stainless steel hopper		○
Sliding hopper		○
Mold temperature controller		○
Auto loader		○
Glass-tube water flowmeter		○
Dryer		○
Dehumidifier		○

YIZUO

THINK
TECH FORWARD